

Simplest and yet very safe suggested OEM vehicle wiring for major benefits of the **Universal LightGenie** in full compliance with traffic regulations anywhere in the world, by virtue of the **LightGenie's** flexible firmware. User benefits include (where permitted by regulations):

- Automatic Night-time Light Turn-on, with selectable Delay Turn-off
- Automatic HiB DRLs or LoB DRLs, with optional Rain-time Running Lights
- Intuitive manual turn-on and automatic delay turn-off of any light, without the need of an ignition key
- User's freedom to turn off all exterior lights any time; and to activate/deactivate DRL in a semi-permanent manner in 5 seconds without any tools (U.S. models)
- Bonus FTP in any main light switch position, even when DRLs are deactivated; in daytime, it turns to DRLs when the dimmer switch is latched in the High Beams position longer than 2 seconds
- Full battery protection when any Head, Park, or Dome lights are left on inadvertently
- 4-minute Head and Park manual turn-on and 4-hour Parking Lights, with automatic turn-off

This Configuration allows the OEM to produce LightGenie-ready vehicles with either 4-Headlamp or 2-Headlamp models to be sold without the LightGenie, giving dealerships more options/benefits to sell on delivery.

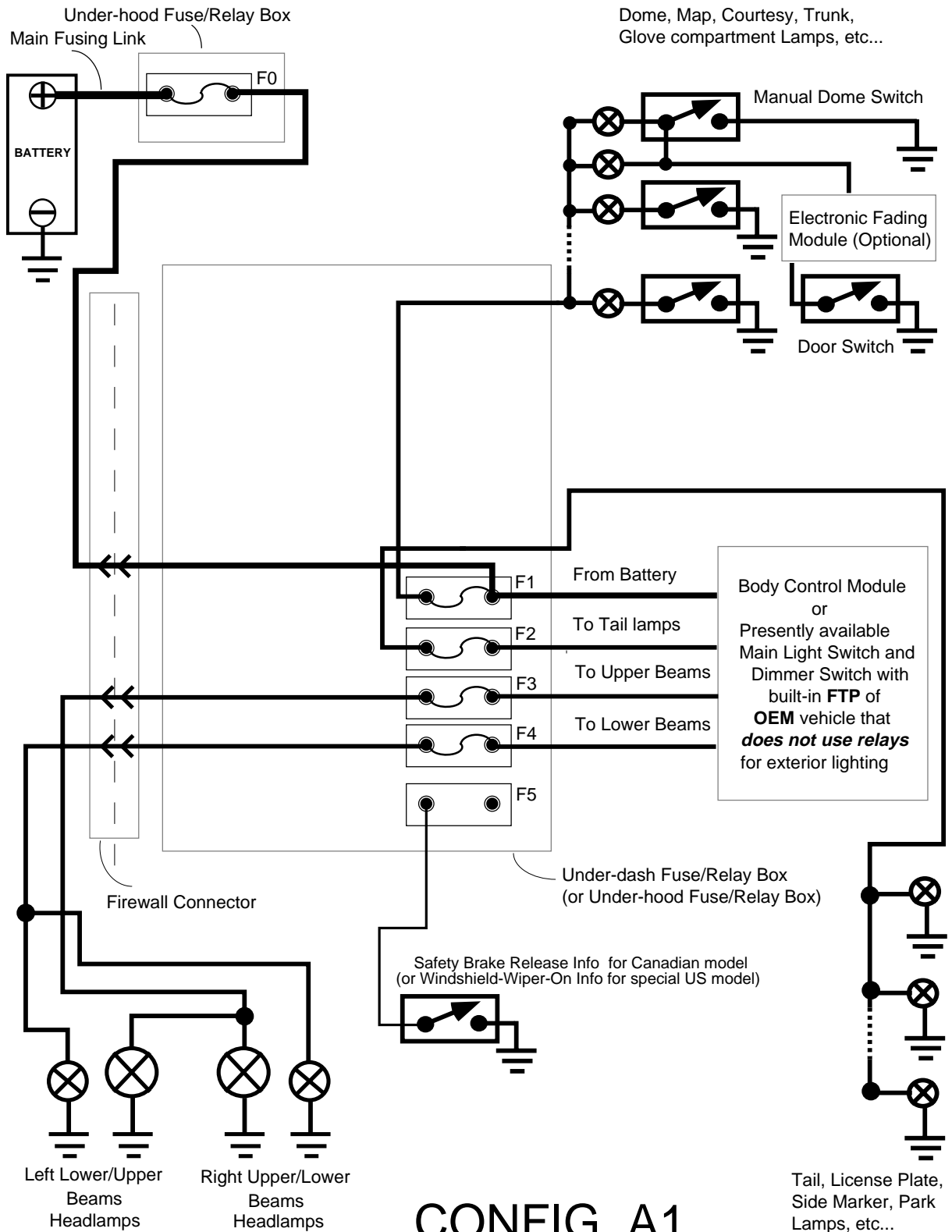

CONFIG. A1

Simplest and yet very safe OEM vehicle wiring with built-in FTP, for the immediate adoption of major benefits of the **Universal LightGenie** in full compliance with traffic regulations anywhere in the world, with or without smart DRLs and/or automatic Raintime Running Lamps

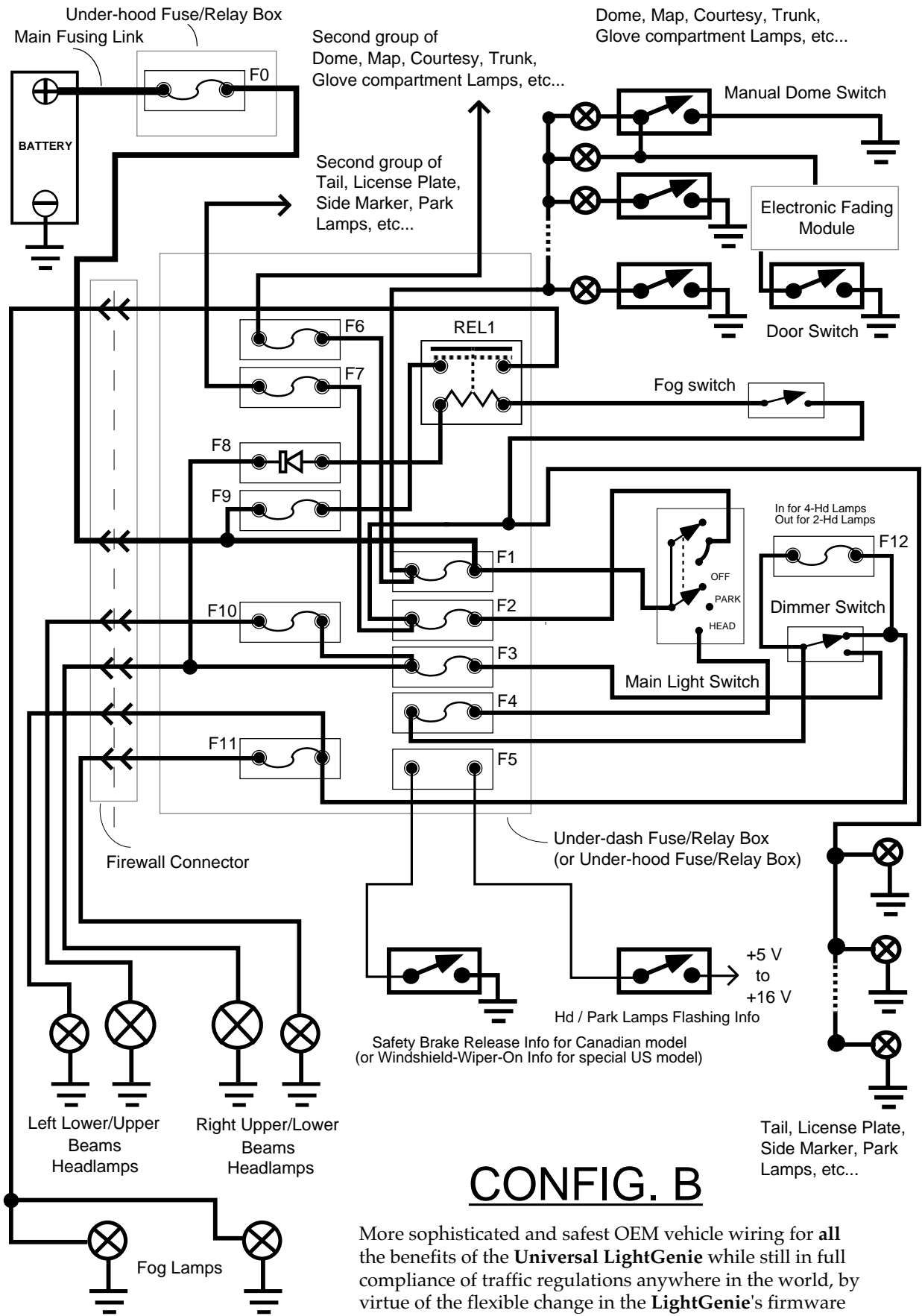

CONFIG. B

More sophisticated and safest OEM vehicle wiring for all the benefits of the **Universal LightGenie** while still in full compliance of traffic regulations anywhere in the world, by virtue of the flexible change in the **LightGenie's** firmware

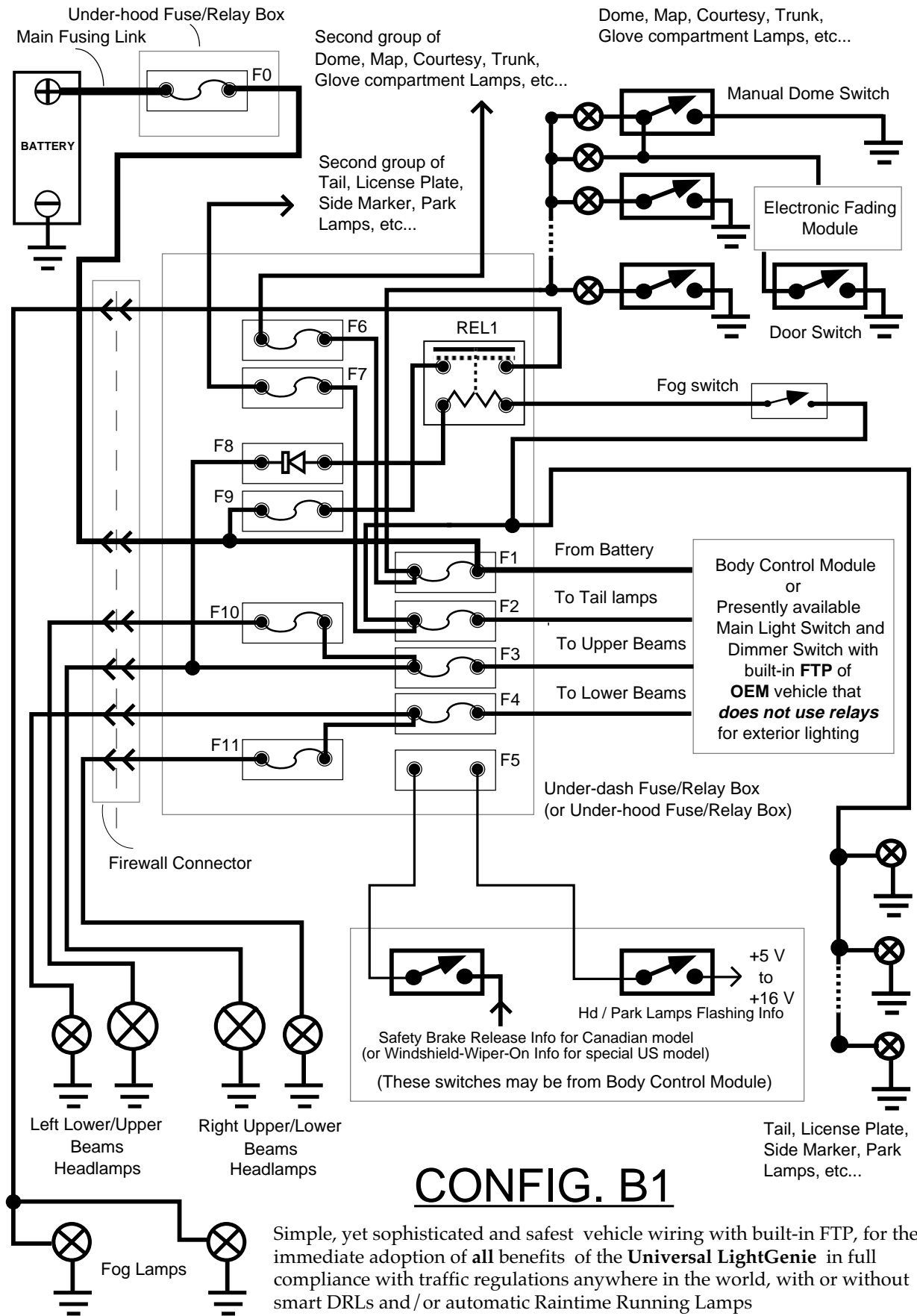

CONFIG. B1

Simple, yet sophisticated and safest vehicle wiring with built-in FTP, for the immediate adoption of **all** benefits of the **Universal LightGenie** in full compliance with traffic regulations anywhere in the world, with or without smart DRLs and/or automatic Raintime Running Lamps

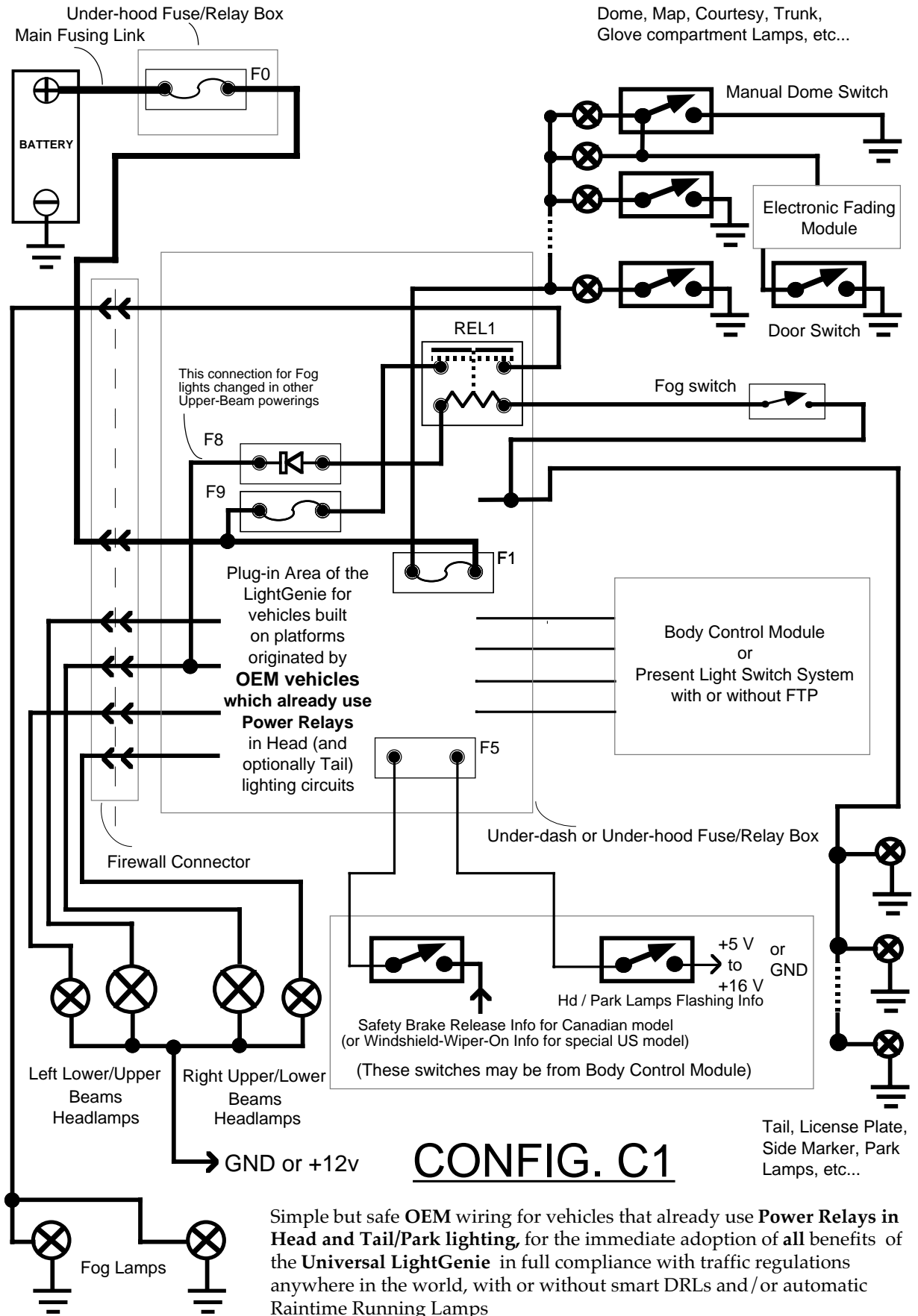

CONFIG. C1

Simple but safe OEM wiring for vehicles that already use **Power Relays in Head and Tail/Park lighting**, for the immediate adoption of **all** benefits of the **Universal LightGenie** in full compliance with traffic regulations anywhere in the world, with or without smart DRLs and/or automatic Raintime Running Lamps